

EXZ

Sub-Atmospheric Back Pressure Regulator



The AURA EXZ sub-atmospheric back-pressure regulator provides adjustable relief of excess positive pressure in systems operating under vacuum caused by pressure buildup or upstream sample injection. The proprietary hybrid spring design operates in conjunction with the EXZ's oversized dual-surface diaphragm to ensure the highest level of precision and repeatability. Multiple seat material options eliminate reaction with the media. This allows the user to accurately throttle excess positive pressure from the system to maintain optimal process conditions.

Each EXZ regulator is assembled in a Class 100 cleanroom as a complete assembly with all gauges, fittings, and valves attached. The completed assembly is 100% helium leak checked and cleaned for oxygen service. Additionally, the EXZ undergoes multiple flow and function tests to meet the harsh demands and rugged environments of any application worldwide.

The EXZ is available with LumiShield™ inert and anti-corrosive technology that provides superior corrosion resistance to exotic metals in highly acidic or caustic applications. The LumiShield's inert surface also eliminates moisture and process media absorption, making the EXZ the ideal choice for accurate and reliable excess positive pressure control in sub-atmospheric applications.

EXZ Features

- 1. Proprietary hybrid spring design**
 - Precision performance under vacuum
- 2. Oversized dual-surface diaphragm**
 - Maximum sensitivity and repeatability
- 3. Multiple seat materials**
 - Ensures reliability by eliminating reaction with media
- 4. Threaded bonnets and rear mounting holes**
 - Able to panel or surface mount

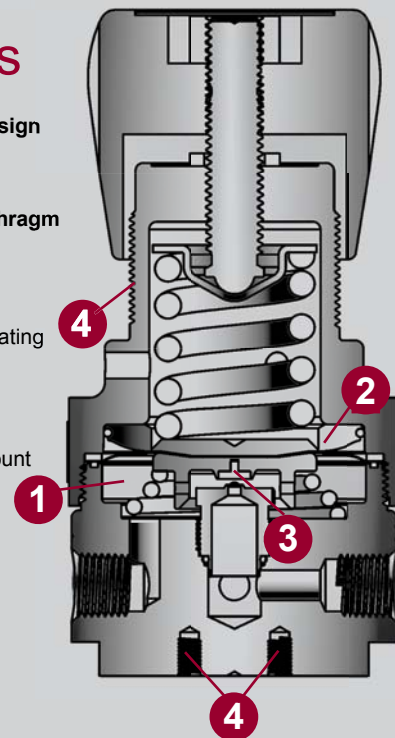

EXZ Sub-Atmospheric Back Pressure Regulator

Technical Data and Product Specifications

Materials of Construction

	EXZS	EXZG
Body	316L stainless steel	LumiShield™
Bonnet	304 stainless steel	LumiShield™
Sensing Element	316L stainless steel	LumiShield™
Seat	Viton, PTFE	Viton, PTFE
Nozzle	316L stainless steel	LumiShield™
Hybrid Spring	Electro-less nickel-plated	Electro-less nickel-plated
O-Ring Seal	PTFE	PTFE

Functional Specifications

Design Pressure	<ul style="list-style-type: none"> Working pressure: 15 psig PTFE/Viton® Burst pressure: > 4x Working pressure 	Temperature	<ul style="list-style-type: none"> PTFE: -40°F to 140°F (-40°C to 60°C) Viton: -40°F to 140°F (-40°C to 60°C)
Maximum Inlet Pressure	<ul style="list-style-type: none"> 15 psig (30 psia) 	Weight (bare body)	<ul style="list-style-type: none"> 4 lbs (2.18 kg)
Leak Rate	<ul style="list-style-type: none"> External: 1×10^{-7} He ccs Seat: 1×10^{-7} He ccs 	Gauges (optional)	<ul style="list-style-type: none"> 2" manufactured to ANSI/ASME B40.1

Typical Application

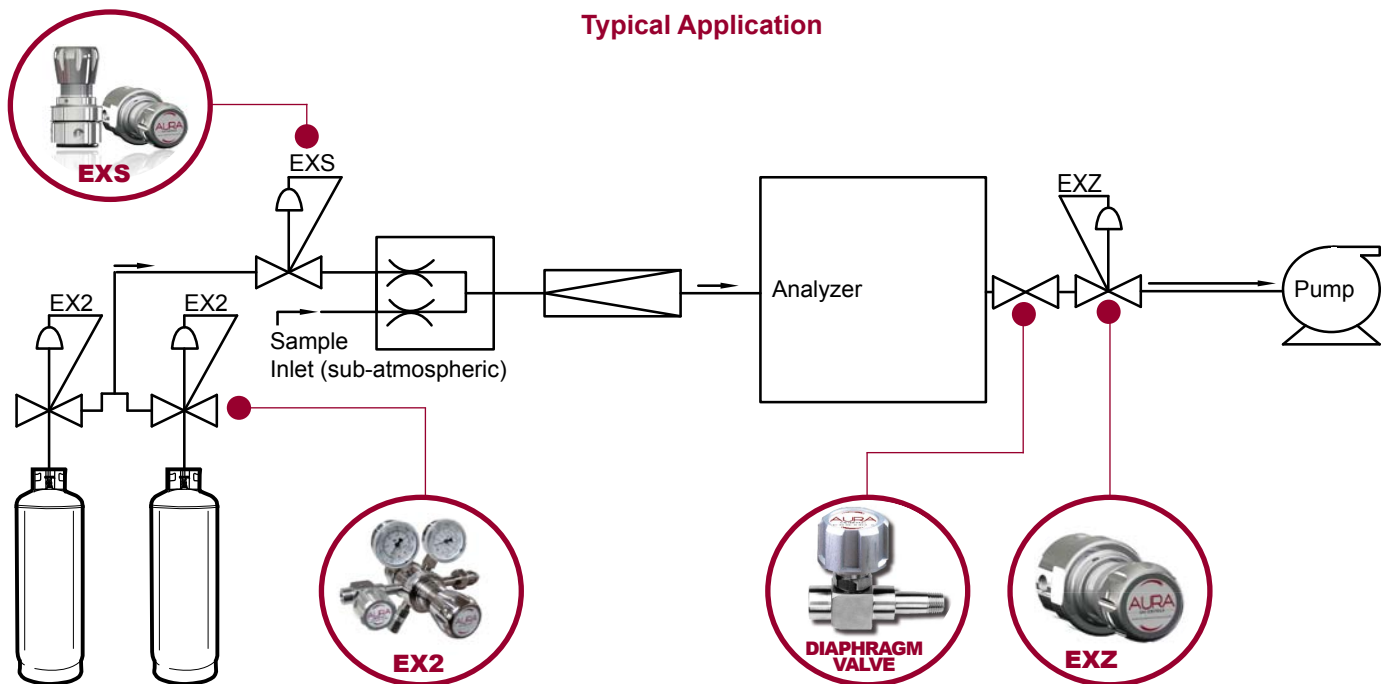

Sub-atmospheric back pressure regulators allow the end-user to precisely and consistently throttle excess positive pressure from systems operating below atmospheric levels. In a typical application, a sample is drawn out of the process line at sub-atmospheric levels for analysis; however, the zero and span gas cylinders introduce positive pressure into the system during calibration cycles. The EXZ sub-atmospheric back-pressure regulator will alleviate any spikes in system pressure caused by buildup or upstream sample injection during analysis and calibration. To introduce calibration gas, the EX2 dual-stage regulator controls the inlet pressure from the gas cylinders while the EXS sub-atmospheric regulator reduces the gas pressure down to sub-atmospheric levels.

Each EXZ regulator assembly includes:

- Class 100 cleanroom assembly
- 100% helium leak check
- Cleaning for oxygen service
- 100% function test
- Silicone-free assembly
- Certificate of conformance
- Certificate of cleaning for oxygen service

Mounting and Installing Information

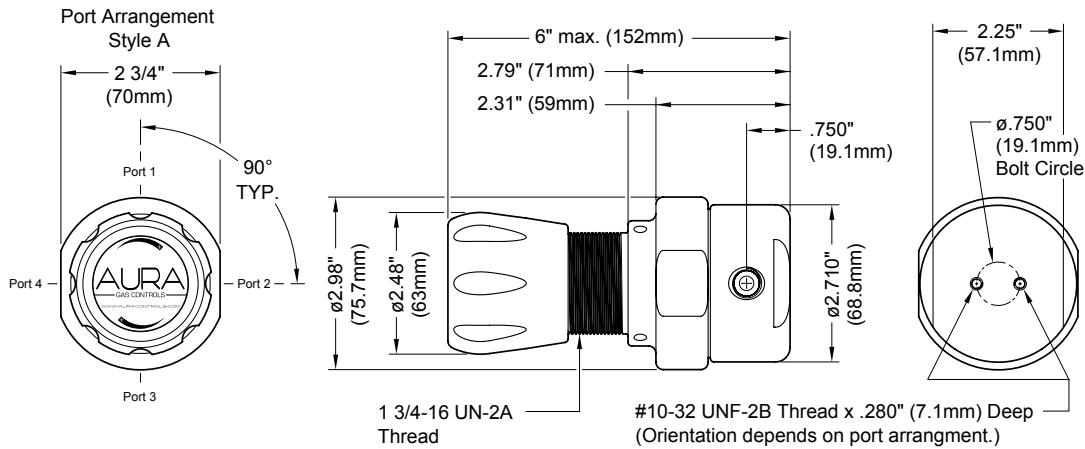

Ordering Information

EXZ 4 5 6 7 8 -01- 13 14 15 - 16 17 0

Digit 4 - Material of Construction

S = 316L stainless steel
G = LumiShield inert and anti-corrosive technology

Digit 5 - Control Pressure Range

1 = 0-15 psig

Digit 6 - Gauges

0 = No Gauges
1 = Inlet Gauge (psig/kPa)
2 = Outlet Gauge (psig/kPa)
5 = Inlet Gauge (BAR/psig)
6 = Outlet Gauge (BAR/psig)

Digit 7 - Sensing Element/Seat

1 = Viton seat
2 = PTFE seat

Digit 8 - Assembly

See the EXZ Port Configuration Table on the back of this brochure for choice of assembly.

Digits 13-15 - Inlet Port

000 = None (1/4" female NPT)
M06 = 6mm ss compression tube fitting
M08 = 8mm ss compression tube fitting
M10 = 10mm ss compression tube fitting
M12 = 12mm ss compression tube fitting
TF2 = 3/8" ss compression tube fitting
TF4 = 1/4" ss compression tube fitting
TF6 = 1/8" ss compression tube fitting
TF8 = 1/2" ss compression tube fitting

Digit 16 - Valve Assembly

0 = No valve
1 = Diaphragm valve
2 = Needle valve

Digit 17 - Outlet Fitting

0 = None
1 = 1/4" male MPT
2 = 1/8" ss compression tube fitting
3 = 1/4" ss compression tube fitting
4 = 3/8" ss compression tube fitting
5 = 1/2" ss compression tube fitting
6 = 6mm ss compression tube fitting
7 = 8mm ss compression tube fitting
8 = 10mm ss compression tube fitting
9 = 12mm ss compression tube fitting

Accessories:

Panel mount kit
EXPA0002-01-000-000

Key:

ss = Stainless steel

NOTE: If you are unable to find a configuration specific to your application's needs, call AURA Gas Controls directly at 800.582.2565.



1501 Harpers Road, Virginia Beach, Virginia 23454

800.582.2565

www.AURACONTROLS.com

Registered ISO 9001



EXZ

Sub-Atmospheric Back Pressure Regulator Port Configuration Table

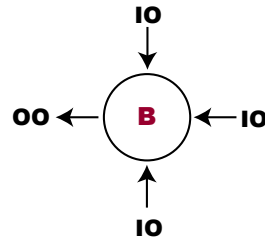
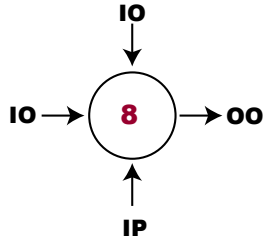
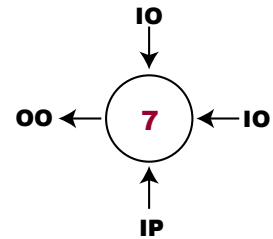
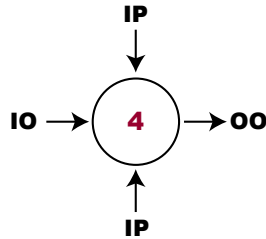
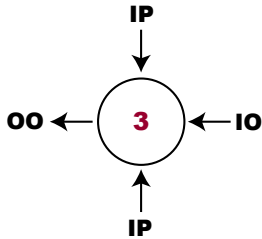

Key:

- OO - Outlet Open
- OP - Outlet Plugged
- IO - Inlet Open
- IP - Inlet Plugged